

# MR PN 10

Gas Pressure Regulator  
Inlet pressure 10 bar  
DN 25 and DN 50



## Applications

Pressure reduction for:

- District distribution
- Industrial uses

## Brief information

The gas pressure regulator MR 10 bar series is spring loaded and fully inlet pressure balanced. The devices have a standard integrated safety shut-off valve (SSV) and a standard integrated limited capacity relief valve (RV). It opens the range of our MR 6 bar up to 10 bar inlet pressure, which is known for excellent regulation and lock-up behaviour and easy maintenance.

The MR 10 bar series is of use for industrial application and small stations.

The unit is to install direct in the line. An additional sensing line is necessary.

The units are approved by DVGW according to the pressure equipment directive 97/23/EC (PED) and accordance with EN 334 / EN 14382.

Registration Number: CE-0085BM0201.

### Technical data:

- Inlet pressure range  $p_U$  200 mbar to 10 bar
- Outlet pressure range  $p_{ds}$  20 to 500 mbar (different setting springs necessary)
- Minimum differential pressure  $\Delta p_{min}$  50 mbar

Pressure set ranges and accuracy classes see table below.

**Ordering example:** Gas governor MR50 SF10 or MR25 SF10 with over and under pressure shut-off valve (identifier "S") and limited capacity relief valve.

- Inlet pressure ... to ... mbar
- Outlet pressure ... mbar
- Over pressure shut-off set ... mbar
- Under pressure shut-off set ... mbar
- Relief valve set ... mbar

## Main features

- Fully inlet pressure balanced
- External impulse
- Sizes 25 mm, 50 mm
- Flange connection PN 16
- Inlet pressure resistant up to 16 bar
- Spring loaded
- Excellent outlet pressure control
- Integrated safety shut-off valve (SSV) for over or over and under pressure shut-off
- Integrated limited capacity relief valve (RV)
- Operation temperatures -20 °C to +60 °C
- Integrated filter

### Options

- Internal impulse up to  
MR25:  $Q = 80 \text{ m}^3/\text{h}$   
MR50:  $Q = 300 \text{ m}^3/\text{h}$
- SSV remote indication
- Blocked relief valve

Pressure ranges & accuracy classes for outlet pressure and safety devices

Regulator			Safety shut-off valve				Relief valve	
Set range	Accuracy class	Lock up pressure class	Over pressure set range	Over pressure accuracy group	Under pressure set range	Under pressure accuracy group	Set range	Accuracy group
mbar	%	%	mbar	%	mbar	%	mbar	%
$p_{ds}$ 20 – 50	AC 10	SG 30	$p_{so}$ 45 – 900	AG <sub>O</sub> 10	$p_{su}$ 6 – 13	AG <sub>U</sub> 30	MR25 20–230 MR50 20–120 above outlet pressure $p_{ds}$	10
$p_{ds}$ 50 – 150	AC 10	SG 20			$p_{su}$ 13 –150	AG <sub>U</sub> 10		
$p_{ds}$ 150 –500	AC 5	SG 10						

# MR PN 10: Gas Pressure Regulator, inlet pressure 10 bar, nominal diameter DN 25 and 50

## Technical data and dimensions

Type	Capacities natural gas [stcm/h]			Connections		LF	Dimensions [mm]			Weight in kg approx.
	at $\Delta p$ 50 mbar	$q_{max1}$	$q_{max3}$	Line	Flanges		H	H1	D	
MR25 (S)F10	15	30	400	DN 25	PN 16	160	276	134	186	6
MR50 (S)F10	40	100	1200	DN 50	PN 16	220	480	180	262	13

$q_{max1} = q_{pmin}$  maximum flow rate at minimum differential pressure  $\Delta p_{min}$   
 $q_{max3} = q_{pmax}$  maximum flow rate at maximum differential pressure  $\Delta p_{max}$   
 Flow rates  $\pm 20\%$  Flange: EN 1092-2

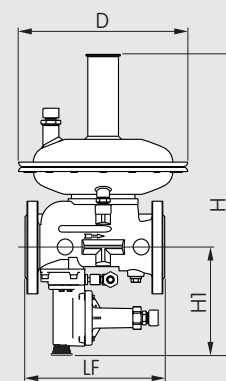
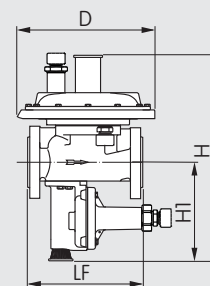

Horizontal installation of the gas regulator

These regulators are suitable for use with previously filtered, non-corrosive gases.

## Maximum capacity

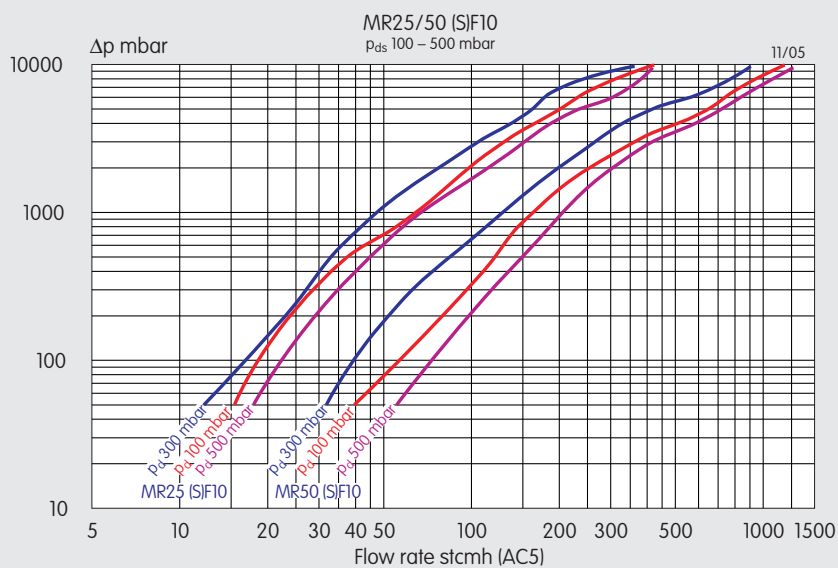
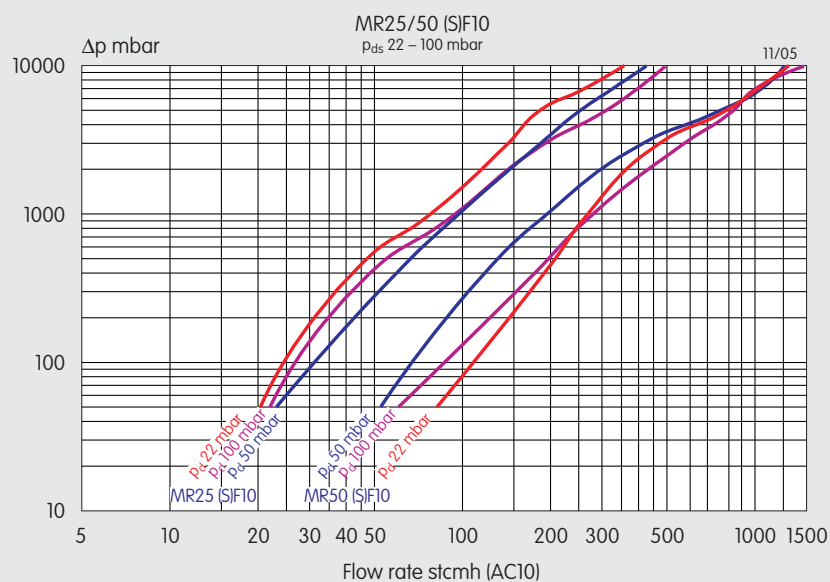

Material Specifications		
	Regulator	SSV
Body	Spheroidal graphite cast Iron: EN-GJS-400-15	Spheroidal graphite cast iron: EN-GJS-400-15
Covers	Sheet steel	Aluminium alloy
Valve seats (orifices)	Brass	Brass
Valve discs and "O" rings	Nitrile synthetic rubber	Nitrile synthetic rubber
Spindle	Stainless steel	Stainless steel
Diaphragms	Reinforced nitrile synthetic rubber	Nitrile synthetic rubber
Bearings	Moulded plastic (POM)	Moulded plastic (POM)
Loading springs	Carbon steel, zinc plated and passivated	Carbon steel, zinc plated and passivated

Spring ranges outlet pressure regulator MR25 (SIF10)						
Order No.	73008974	73008950	73008975	73017779	73017667	73018630
Adjuster ring	33470005	33470005	33470005	73002114	73009514	73009514
Set range	19 – 32	25 – 50	45 – 70	55 – 130	120 – 300	250 – 500
Colour	ochre	light blue	blue	yellow	anthracite	black

Spring ranges outlet pressure regulator MR50 (SIF10)							
Order No.	73018431	73018432	73018433	73018434	73018435	73018436	73018437
Set range	20 – 30	25 – 50	45 – 100	90 – 200	150 – 300	250 – 400	350 – 500
Colour	white	yellow	green	blue	red	brown	black

Spring ranges SSV					
OPSO					
Order No.	73008954	73008955	73008956	73008957	73018496
Adjuster ring	73011076	73011076	73007626	73007626	73007626
$p_{so}$	31 – 67	59 – 138	117 – 276	236 – 470	450 – 900
Colour	orange	white	light blue	yellow	black
UPSO					
Order No.	73010871	73008959	73008960		
$p_{su}$	6 – 18	16 – 49	47 – 146		
Colour	yellow	white	light blue		

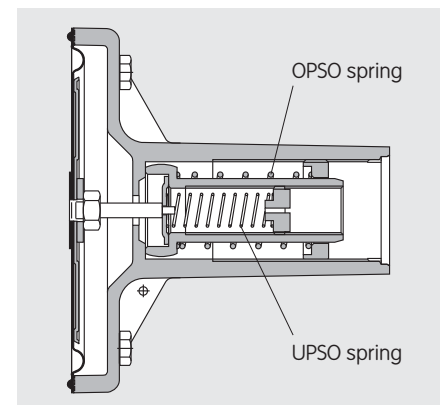

Spring ranges Relief Valve			
Order No.	73012343	33470052	73010839
Regulator	set point in mbar above $p_{ds}$		
MR25 (SIF10)	8 – 90	15 – 125	100 – 230
MR50 (SIF10)	6 – 40	16 – 54	40 – 120

Set points in mbar (set points for horizontal installation)

Accessories	
Order No.	Description
73018370	Damping Valve
73018985	MR50 conversion kit for internal impulse regulator and SSV
73018966	Remote indicator SSV
73020316	Soft spares kit MR 50 PN10
73020317	Soft spares kit MR 25 PN10

# MR PN 10: Gas Pressure Regulator, inlet pressure 10 bar, nominal diameter DN 25 and 50

## Connecting patterns

Diameters for exhaust pipe	
Length	Min. line diameter
< 3 m	DN 15
3 – 5 m	DN 20
5 – 10 m	DN 25
> 10 m	DN 50

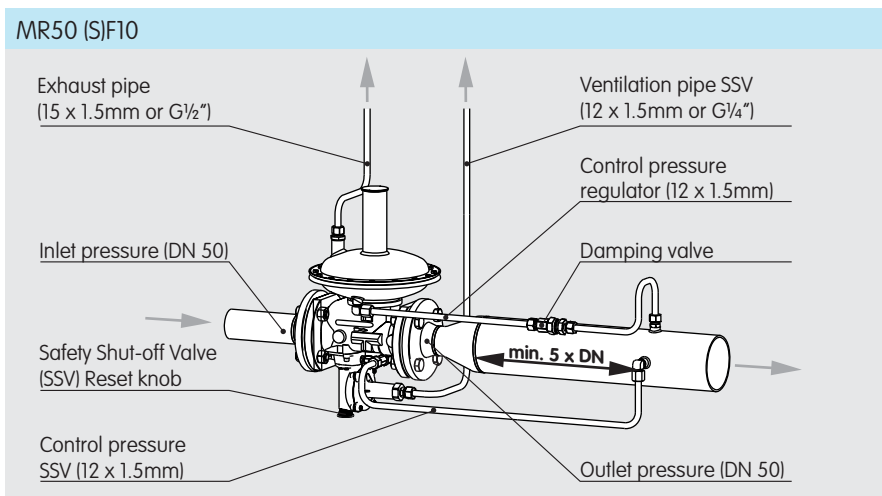
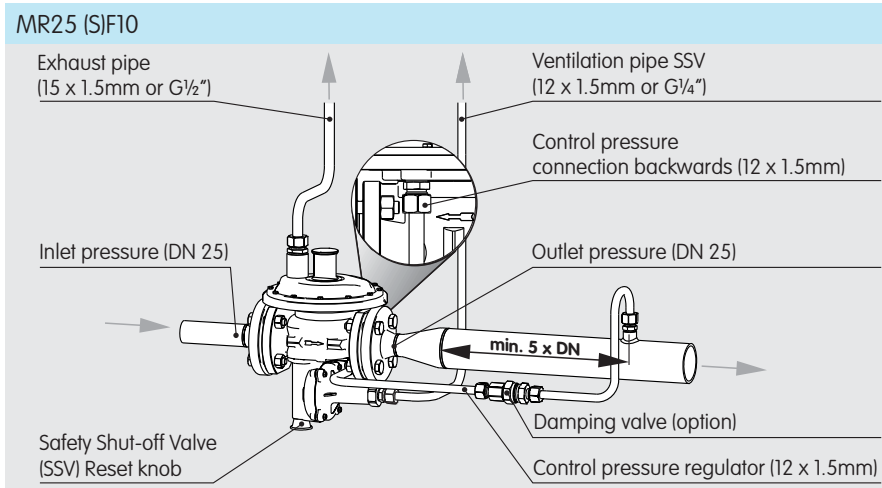

## Installation

- The installation position is preferably horizontal. The outlet pressure is factory set in the horizontal position (referring the position of the main diaphragm). In case of other installation positions, a subsequent adjustment is required under certain circumstances.
- The devices of the MR PN10 series are, in general, connected with an external impulse connection (e.g. 12L). Optionally, it is also possible to use the internal pulse up to a flow rate of 300 m<sup>3</sup>/h (MR 50) or 80 m<sup>3</sup>/h (MR 25) (ordering option in case of MR 50 or please see accessories for retrofitting).
- The devices having a nominal width

of DN 50 are, in principle, supplied with a damping valve, which shall be installed in the line for the external impulse. In addition, the SSV shut-off valve must be connected – in case of this nominal size – by means of an external impulse line (please observe the operating instructions).

- When connecting an external impulse line, it is absolutely necessary (to ensure that the quality of regulation is maintained) that the downstream line has the same nominal size of the pipe, a minimum length of 5 x DN and consists of a straight piece of pipe. The external impulse can be connected

either upstream or downstream of a possible expansion.

- Any exhaust or ventilation pipes for the gas pressure regulator (15 x 1.5 or G1/2") and the SSV shut-off valve (12 x 1.5) shall be connected in accordance with the connecting pattern and shall be led out of the housing.
- It is recommended to install a gas filter upstream of the gas pressure regulator.
- In addition, it is necessary to install a valve each upstream and downstream of the gas pressure regulator.

## Your contacts

Germany  
Elster GmbH  
Steinern Str. 19 - 21  
55252 Mainz-Kastel  
T +49 6134 605 0  
F +49 6134 605 223  
www.elster-instromet.com  
info@elster-instromet.com

Belgium  
Elster-Instromet N.V.  
Rijkmakerlaan 9  
2910 Essen  
T +32 3 670 0700  
F +32 3 667 6940  
www.elster-instromet.com  
info@elster-instromet.com

Singapore  
Elster-Instromet Sdn. Bhd. (Singapore Branch)  
160 Paya Lebar Road  
#04-01 Orion@Paya Lebar  
Singapore 409022  
T +65 6247 7728  
F +65 6247 7729  
sales@elster-instromet.com.sg

MR PN10 EN06

A21.09.2009