



## ERG-M SERIES

PN0,5 Mini Gas  
Pressure Regulator

**ESKA**  
VALVE

[www.eskavalve.com](http://www.eskavalve.com)



## ERG-M SERIES

PN0,5 Mini Gas  
Pressure Regulator

Patented  
Design

%100 Quality  
Control



### INTRODUCTORY AND TECHNICAL INFORMATION

- ERG-M series gas pressure regulators are used in the gas lines in order to reduce maximum 0,5 bar input pressure to the desired output pressure between 16 and 100 mbar. The range of the output pressure can be set with the choice of a different spring
- Usage: City networks for domestic use
- Fluid Type: Second Family Group H Medium - Non-corrosive gases such as Natural Gas (Methane), LPG, Propane, Butane, Town Gas, Air, etc...
- Pressure Class: PN0,5
- Connection or Port Size : 1/2", 3/4" Threaded (Female)
- Inlet Pressure Range: 50mbar up to 0,5 bar
- Outlet Pressure Range: 16 mbar up to 100 mbar
- Flow Range : 0-10 m<sup>3</sup>/h
- Filter : Pore dimensions as standard 50 micron (10-20 microns on request)
- Number of Stages: Single Stage
- Accuracy Class: AC 10 (± 10%)
- Closing Tolerance: SG20 (+ 30%)
- Ambient Temperature: -20°C up to 60°C (On request -40 °C)
- Class and Group: A Class Group 2 (A2)
- Pressure Test Connection: 1/8" Threaded (Female)
- Material Standard: Aluminum-EN 1706 / Brass-EN 12164 and EN 12165 / Rubber-EN 549 / Plastic-EN 11667
- Materials: Body and cover- EN AC 46100 Aluminum / Some Internal Parts - CuZn39Pb3 Brass, Nylon or POM Plastic / Some External Parts- CuZn40Pb2 Brass / Rubber NBR / Spring- AISI 302

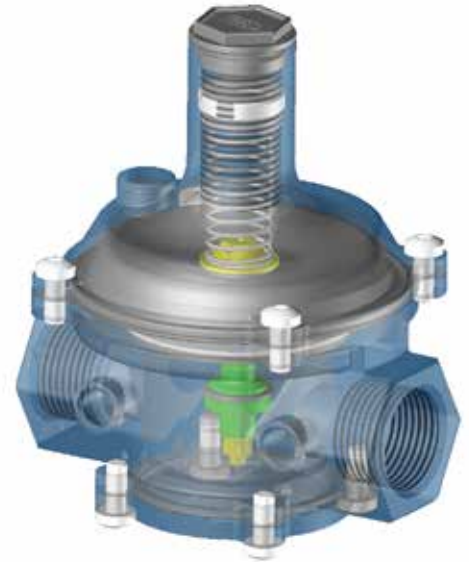

CONNECTION	OUTLET PRESSURE (21mbar)
1/2"	10 m <sup>3</sup> /h
3/4"	10 m <sup>3</sup> /h

FLOW RATE TABLE (FOR NATURAL GAS)

MODEL NAME	CONNECTION	UNIT WEIGHT	BOX SIZE (LxWxH cm)	PACKAGING (pieces/ carton)	CARTON SIZE (LxWxH cm)	CARTON (weight)	TOTAL CARTON (weight)
ERG-M 1015	1/2"	0,50 kg	10x9x13	50	50x50x30	0,85 kg	25,85 kg
ERG-M 1020	3/4"	0,50 kg	10x9x13	50	50x50x30	0,85 kg	25,85 kg



# ERG-M SERIES

PN0,5 Mini Gas  
Pressure Regulator

Patented  
Design

%100 Quality  
Control



## FLOW DIRECTIONS

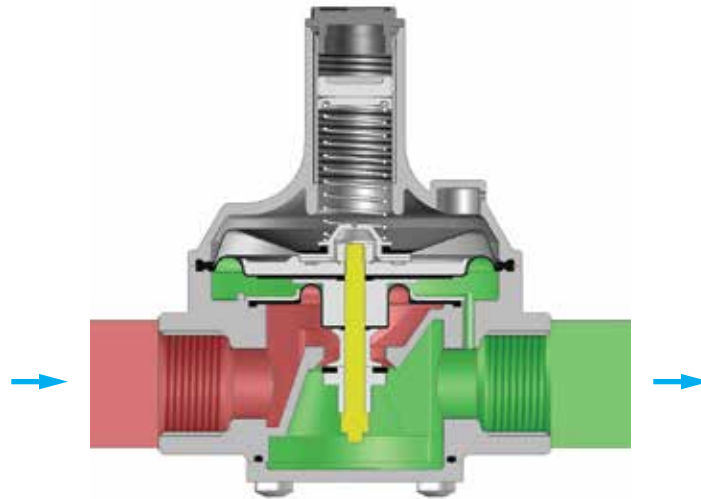

INLINE

## OPTIONS

TESTING PORTS ON BODY



PERMANENTLY SEALED  
PLASTIC CAP



## SIMILAR PRODUCTS



ERG



ERG-E



ERG-L



# ERG-M SERIES

PN0,5 Mini Gas  
Pressure Regulator

Patented  
Design

%100 Quality  
Control



## DIMENSIONS (mm)

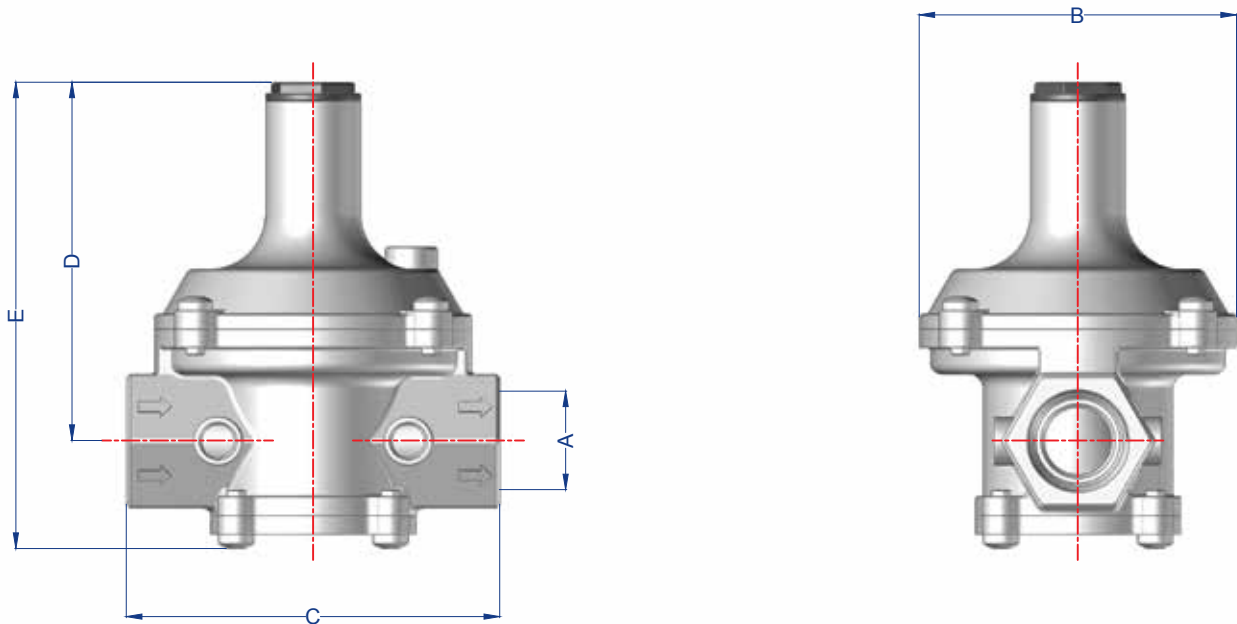

MODEL	A	B	C	D	E
ERG 1015	1/2"	85	100	95	124
ERG 1020	3/4"	85	100	95	124