

Profiles

Customer Magazine 2/2017



Center of Excellence for Repairs at Mainz-Kastel

evohome System: Electronic Room Temperature Control

Smart Metering Rollout in Europe

Total Care Field Instrumentation Services

Focus on Service and Support



Justin McCurnin

*Sr. Marketing Director
Honeywell Process
Solutions
Process Measurement
and Control*

Last week, my wife and daughter had the unfortunate event of having the battery and alternator die in our car. It was the first time I've had any problems with it. I credit regular servicing of the vehicle and my impeccable driving skills. The car needed to get fixed quickly because I was planning to give it to my daughter. She just turned 16 years old and is beginning to drive on her own. If you plan on visiting Minnesota in the next 6 months, I'd recommend watching out for her.

I took the vehicle to the same technicians I've been taking it to for the last three years. If you are wondering why my wife and I take our cars to the same technician, it is because of one thing...trust. For me, I trust these people will do what is necessary to make this car run safely at a fair price. It's even more important to me now because the last thing I want to be worrying about is my daughter being stranded somewhere. It could even be a place without WiFi and she'd lose her streaks on SnapChat.

My own experience with my vehicle makes me reflect on what service means at Honeywell. When it comes to servicing your metering equipment, we strive to ensure reliability from the start with a company you can trust. As the original product manufacturer, we feel responsible for supporting our customers in maximizing the output, efficiency, reliability, and safety of their installations. We will always ensure that our products are used and maintained in the best possible condition. This is why, for over 150 years, we have been building best in class

metering equipment as well as providing committed service and support to our customers.

In addition to trust, whether you have a single meter or a complex integrated metering system, we offer you a chain of lifecycle services around the world, designed to ensure continuous confidence in your measurement results. Our service centers are the one-stop resource for all your meter needs.

As the owner of a Honeywell product, keeping up with regular scheduled maintenance has never been easier. Even if you have a maintenance shop of your own, we can help with the overflow work caused by holidays, illness, and lack of bandwidth or domain knowledge.

Service is also becoming smarter with connectivity. The world is becoming more connected and Honeywell is helping to lead the way in homes, buildings and industrial sites. Honeywell connectivity is taking service to a new level with remote diagnostics and repairs which leads to fewer surprises for you, lower operating costs and a better experience for your customers.

I think we can all imagine a world where our meters tell us they have a problem, what the solution is and when to fix it. This will hopefully lead to greater safety which we need when certain parts of the world have 16-year-olds driving cars.

Yours
Justin McCurnin

Publisher

Elster GmbH
Steinern Straße 19-21
D-55252 Mainz-Kastel
T +49 (0) 6134 605-0
www.elster-instromet.com

Editorial staff

Gudrun Biedermann
Marketing Communications
T +49 (0) 6134 605-218
gdrun.biedermann@honeywell.com
 Swetha Nagpal
swetha.nagpal@honeywell.com

Contact

customerfirst@honeywell.com

Authors

Axel Bußkönning, Germany
Pierre Dufour, USA
Cees Euser, The Netherlands
Sascha Bluhme, Germany
Max Gutberlet, Germany
Sebastian Hintz, Germany
Carsten Lorenz, Germany
Daniela Lücke-Janssen, Germany
Hans-Peter Smid, Germany
Rüdiger Pfeil, Germany
Louis Oquendo, The Netherlands
Tim Vogel, Germany

Articles signed by the author reflect their personal opinion.

Photo credits

Page 8: © iStockphoto.com/kotoffei
Page 9: © iStockphoto.com/Tashi-Delek
Page 10-13: © iStockphoto.com/Nikada
Page 17: © iStockphoto.com/golero
Page 25: © iStockphoto.com/sturti

Publishing dates:
Three editions for the year 2017

Honeywell customer magazine online:
www.elster-instromet.com/en/index

As a Manufacturer, We Can Cover All Requirements at a Single Site!

The installed base with sophisticated components is increasing constantly which means that so are the challenges for expert operation. Thus, good after-sales service is not something that happens by chance, it is the result of careful planning and the optimized use of resources.

Honeywell, as the manufacturer, provides you with support to maximize the reliability and safety of installations. Perfect repairs and recalibrations are a core area of our range of services. These are explained in greater detail below.

The Mainz-Kastel site is YOUR partner for the repair, conversion, and recalibration of all products supplied by Honeywell. As a manufacturer, we feel responsible for providing the best possible service. Honeywell's mission is to guarantee the productivity, reliability, accuracy, and safety of all products and measuring systems. Our aim is to ensure that our high-quality products

are always state of the art. Honeywell provides durable, reliable, and sophisticated measuring equipment which can be updated to meet the latest technical standards years or even decades later. To ensure this, all departments – Production, Technology, Quality Management, and Repairs – must be interlinked.

Why is this so important?

The empirical values from each department are exchanged with the others so as to help continuously improve our products and processes. For example, findings from our development work and product lines are directly used in our Repairs department. Customer feedback





and customer needs recorded by our Repairs department are in turn used in our corporate processes. This is also ensured by the so-called “Honeywell Operating System” (HOS). Our entire workforce and all our processes are included in this corporate philosophy to ensure safety, quality, fast delivery, and solutions to problems as well as continuous improvement. This means that all our departments can learn and benefit from each other, which in turn provides benefits for the customers. As a man-

ufacturer, it makes just as much sense to combine our Repairs department at a single site, the Center of Excellence, with all the current production lines in order to ensure the best possible use of resources and generate maximum value for our customers.

Repair Services

Repairs: After an extensive incoming inspection, we prepare an individual repair quotation. Depending on the customer’s wishes or require-

Repairs, conversion, recalibration, and spare parts supply at the Mainz-Kastel site

Turbine gas meters	 TRZ	 SM-RI / Q75	 Q/QA
Rotary gas meters	 RABO	 RVG	 IRM
Ultrasonic gas meters	 Q.Sonic plus	 Q.Sonic C-Type/S-Type	
Gas pressure regulators	 MR50	 HR100	
Compact & industrial volume converters	 EK series	 FC series	
Data loggers & industrial modems	 DL series	 Industrial modems	
Gas chromatographs	 EnCal	 GasLab	



ments, this quotation can extend from minor work to the complete replacement of measuring components. The devices are updated to meet the latest technological standards using original spare parts.

Conversions: We can complete a range of different modifications to the devices if requested. Prior technical clarification is required for this. Examples of modifications include:

- Updates of software for electronic products
- Installation of pulse generators on the index, etc.

Recalibrations: We can complete national recalibrations (Germany) and international calibrations at our accredited testing laboratories (ISO 17025) in Mainz. The infrastructure at the site also includes a high-pressure test rig (5 – 1750 m³/h; up to 25 bar (air)).

Replacement Devices/Loan Devices: After a technical discussion and availability check, we can provide appropriate replacement or loan devices (turbine & rotary gas meters).

Sebastian Hintz sebastian.hintz@honeywell.com

Return documents

We require meter-relevant information to guarantee smooth repair processing. You can download our repair processing form for meters and regulators from the Internet using the following link:

www.elster-instromet.com/en/repairs



ELSTER – Customer Return Delivery Note		Meters / Regulators		Honeywell	
<small>For questions, please contact your local sales organisation/ Sebastian Hintz or Lukas Czeiger who are responsible for repairs in Mainz T: 0049 (0)6134 605 469 or 136 F: 0049 (0)6134 605 310</small>					
Customer:					
Name:	Telephone number:	Date:			
Company:	Metering point:				
Competent contact person at Elster:					
Name:	Ticket No.:	Date:			
Note:					
Quantity of devices (please enclose one return delivery note for each device)					
Total quantity:	Page:	of _____			
Repair data <input type="checkbox"/> Compliant <input type="checkbox"/> Repair *) <input type="checkbox"/> Check-up <input type="checkbox"/> Upgrade					
Device:	Serial No.:	Year:			
Operating pressure:					
Is a high-pressure test required? (only for turbine meters)					
Upgrade request:					
Full compliant description:					
Note:					
<small>*) After the device has arrived at our premises, it will be checked and you will receive a detailed estimation of costs for the proposed repair. We will then require a written answer on how to proceed.</small>					
German delivery address					
<small>Please clarify where to send the devices with your local sales organisation. In case of a German delivery destination, please return the device including this return delivery note to:</small>					
Elster GmbH, Reparatur, Steinernstraße 19-21, D-55252 Mainz-Kastel, Germany					

Please get in touch with your local sales and service contact in order to discuss the best procedure for recalibration and repair of Honeywell meters and electronic devices.

evohome System: Users Have Full Control in the Palm of Their Hand!

The high costs of heating homes are a burden to both owners and tenants. Furthermore, conventional, manually adjustable thermostat valves on radiators are soon out of their depth when certain rooms have to have a certain temperature at a certain time – for example, a bathroom at 24°C as soon as you get up in the morning.

Smart individual room control systems such as evohome from Honeywell Heating Controls deliver improved heating comfort and lower heating costs. They combine very high heating and control comfort with maximum savings – reducing heating costs by up to 30 percent. But the best thing is that the whole system can be controlled very easily with an app. In addition, a wireless alarm system can be controlled and monitored using the app – evohome Security.

Wireless Smart Zoning Technology

evohome is a modern wireless control unit which can manage a whole range of control tasks – from radiator and panel heating systems, mixed systems to zoning tasks and boiler controls. The heart of the single room control system is a controller unit with touchscreen control. Residents who also want to monitor and control their evohome single room control system(s) remotely require the evohome “Total Connect Comfort International (TCCI)” app for Apple and Android smartphones and tablets and also for the “Pebble” smartwatch.

Easy Programming for Everyday Use

The evohome heating control system allows individual time and temperature programs for up to twelve rooms or zones with up to six switching points per room and day. This smart zoning technology makes the system suitable

for use in detached and multi-occupancy houses and also in buildings with mixed use. All individual values, heating schedules and basic settings can be set easily using an intuitive user interface on the controller or using the app – from your sofa or from anywhere else. The entered data are transferred wirelessly to the adjusting devices if necessary.

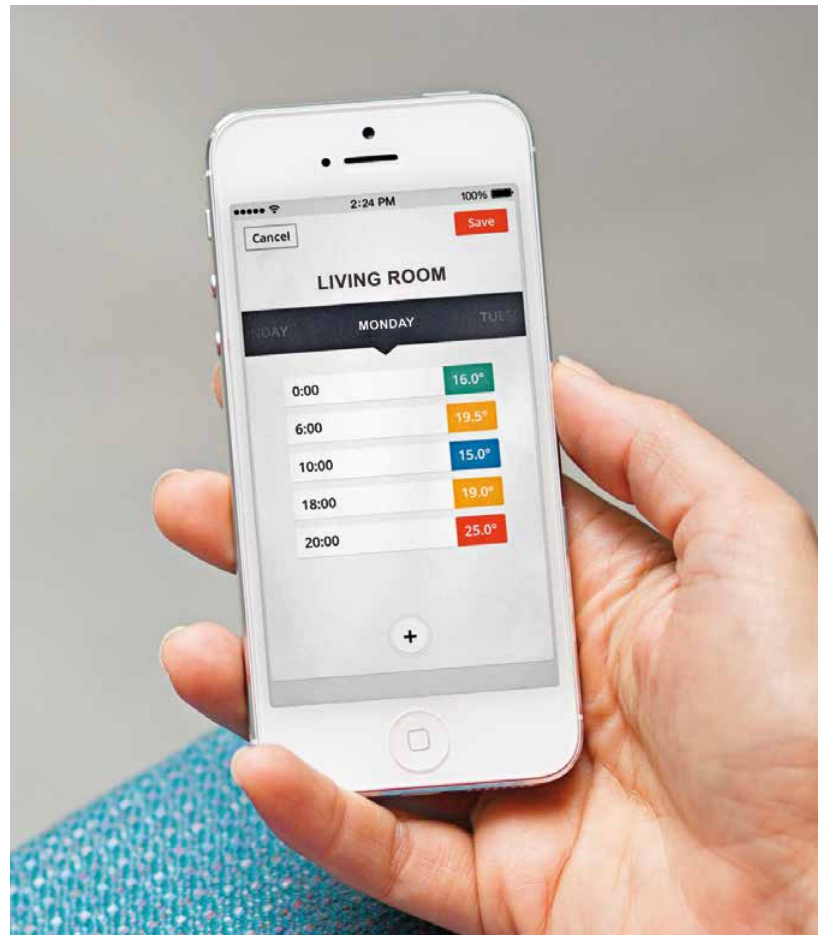

TCCI App



*Full Control Wherever
You Are*

In addition to the standard settings, users of the control system also have “Action” programs available which can be enabled and disabled quickly by pressing a single button, thus making the whole system even easier to use. For example, the “Absent” function starts a previously defined temperature reduction in timer mode (for 1 to 99 days) for all rooms. Two other functions combine economy with heating comfort: “Optimum start” (automatic warm-up) enables the controller to move the activation time of the heating system forward so that the room temperature has been reached by the time set in the timer program. The programmed warm-up rate is adjusted to the relevant room during operation using fuzzy logic. “Optimum stop” switches the heating system off earlier to use residual heat. The aim, however, is only to fall 0.5°C below the programmed room temperature.

Everything at a Glance – evohome Security Alarm System

evohome Security is a wireless alarm system which is easy to use via an app to provide security and control wherever the user may be. At the core of the new Honeywell alarm system is the evohome Security control centre. The compact device communicates wirelessly with the system components, whether they are motion sensors, glassbreak detectors, door/window contacts, CO and smoke detectors or

panic switches – all the alarm functions can be monitored, enabled and disabled using the evohome TCCI app. If an alarm is triggered, the user receives a message on their smartphone and can react immediately and also check the reason for the alarm. If a motion sensor with an integrated camera emits a signal, the security system saves live image data and the house owner can access them directly. If everything is OK, all it takes is a fingertip to mute the alarm system.

evohome Security has up to 32 wireless components which are easy to install using modern 868 MHz wireless technology, thus reducing cost. If the user requires more functions, the system can be easily expanded.

Energy Saving and Security in a Single App

The TCCI app, which previously only controlled the evohome smart heating system, now combines the alarm system and heating control. If, for example, the alarm system is armed because the users are leaving the house, a function in the app can also automatically reduce the heating system temperature. This means that the system saves energy costs while also providing security – regardless of where the residents are.

www.honeywell-haustechnik.de

Ready, Set, Go!

The GasLab Q2 is a gas quality analyzer for natural gases. It determines the heating value, Wobbe index, and other parameters of the sample gas. With all systems becoming increasingly complex, it should be a relief that we can finally talk about something simpler. When it comes to determining the heating value of natural gas, we often use a gas chromatograph. This word is already hard to pronounce but have you ever heard how a gas chromatograph works?

In gas chromatography, the mobile phase is a carrier gas, usually an inert gas such as helium. The stationary phase is a microscopic layer of liquid or polymer on an inert solid support, inside a piece of glass or metal tubing called a column. The gaseous compounds being analyzed interact with the walls of the column, which is coated with a stationary phase. This causes each compound to elute at a different time, known as the retention time of the compound. Comparing the retention times is what gives GC its analytical usefulness. The different eluting components are detected by a thermal conductivity sensor at the end of the column. The signal from this detector is integrated into an area that is proportional to the concentration of the passing component. The components give rise to the heating value, density, and other important parameters of natural gas.

Confused already? Don't even get me started on the installation or commissioning of the online gas chromatograph, calibration gas certificates, integration parameters, calibration

alarm limit settings, pressure tuning of columns, bake-out procedures and so on.

Things are so much easier with the GasLab Q2: Power on with the sample gas and binary mixture on the calibration port. Set the pressures and flows and you are good to go. The design of the analyzer makes it so easy to operate that even my nine-year-old son could get the unit to work.

The device is flame-free and works quickly and continuously. The correlative measuring principle of the GasLab Q2 is based on determining the infrared absorption and thermal conductivity of the sample gas. If you know the IP address, you can simply use Modbus over TCP/IP to communicate with it. No fuss, no worries. The integrated interactive display shows the measurement values and operating conditions of the analyzer. The analyzer can be operated via a touch panel or by using a web browser connected to the device. In addition, computer software can be used for configuration, data display, and recording purposes.

The GasLab Q2 stands out on account of its low capital investment and maintenance costs and its user-friendly operation. It provides you with virtually the same as a gas chromatograph at a much faster rate and with simpler installation. So, ready, set, go! For the GasLab Q2.

Hans-Peter Smid | hans-peter.smid@honeywell.com



Honeywell MasterLink R510

Honeywell’s MasterLink is an integrated software solution that works across the entire gas portfolio. It provides a single software package to configure, calibrate, and access data from the gas volume corrector.

The software’s intuitive dashboard enables users to quickly determine the overall health status of the instrument. Employing standardized terminology, it is easy to configure and calibrate instruments, import data, and generate reports and graphs – eliminating time-consuming manual effort.

Earlier this year, the MasterLink software underwent a total redesign of its user interface to help improve the productivity of operators and technicians, and to offer better compatibility with the latest operating systems across mobile (iOS and Android) and personal computer (PC) platforms, increased automation, and powerful wizard support while retaining a configuration philosophy familiar to users.

This summer, MasterLink has been updated to support the entire Mercury instruments offering (from the latest EC 350 gas volume correctors, ERX 350 pressure recorders or CNI4 data loggers to the legacy Mini-Max, Mini-AT, ERX, Turbo Monitor/Prover/Corrector products), making it the configuration tool of choice for the Mercury instruments offering.

The MasterLink software provides:

- Automation of routine configuration and calibration tasks.
- Increased productivity and cost savings.
- Single tool to configure both corrector and cellular radio.

With the right choice of gas volume corrector software and the supporting ecosystem, utilities supplying natural gas can increase their productivity, lower operating expenses, and realize more value from investments. By becoming an early adopter of innovative solutions like MasterLink, they can also minimize their downtime, generate more return on installed assets, leverage current industry trends, and prepare their operations for a challenging future.

Pierre Dufour pierre.dufour@honeywell.com

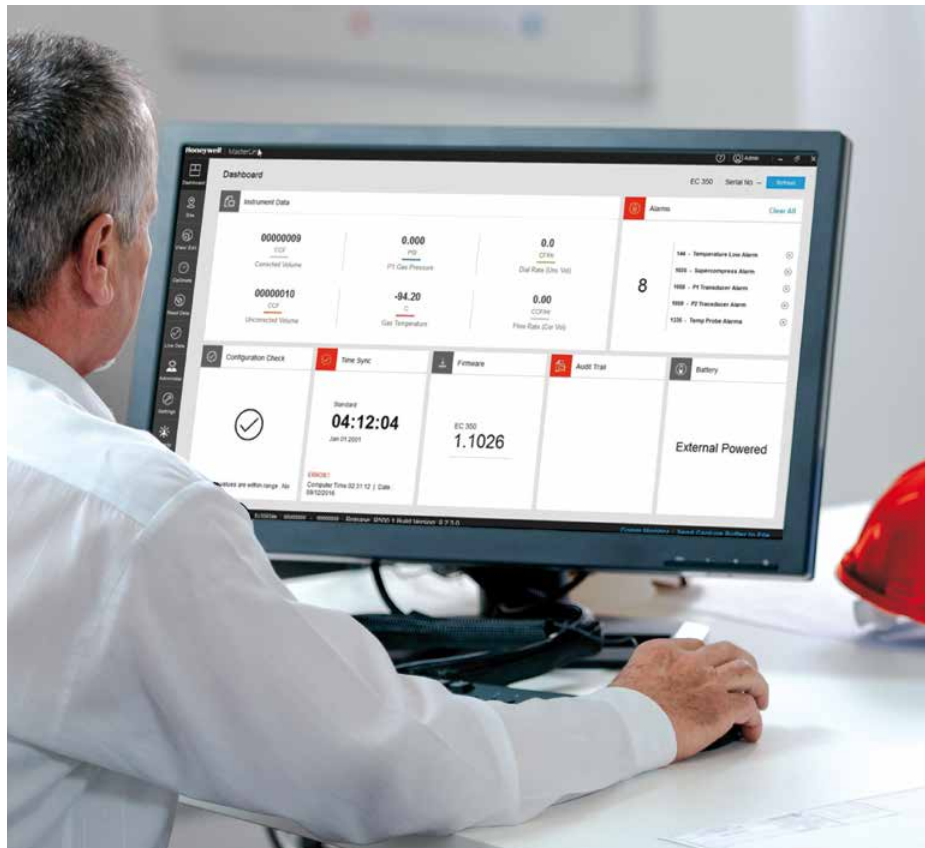

Honeywell Supplies Next Generation of Smart Gas Meters

On the basis of the European Directive on Energy End-Use Efficiency and Energy Services (2006/32/EC), the Economics Ministry in the Netherlands implemented legal regulations on the installation of smart meters for electricity and gas at a very early phase.

As a result of this situation, Dutch network operators count among the pioneers of smart metering in Europe. The main objective is to provide households and commercial metering points with smart meters by 2020.

Between 2011 and 2013, Dutch network operators prepared joint specifications (Dutch Smart Meter Requirements, final version DSMR4.2.2) and thereafter installed significant numbers of these electricity and gas meters. Honeywell could be described as the “first supplier” and initially supplied the network operators with gas meters featuring Absolute ENCODER technology before an electronic index was developed and successfully introduced to cover the complex functional requirements. Over 360,000 installations in the Netherlands alone indicate the reliability and robust nature of the first generation of Honeywell’s electronic index in practical use.

For the mass rollout, Dutch network operator Enexis Netbeheer used a new tendering process in 2014 for smart electricity and gas meters on the basis of its own specifications, the so-called Enexis Smart Meter Requirements (ESMR5). Gas and electricity meters

communicate with each other using wireless M-Bus (868 MHz) pursuant to ESMR5, which is based on EN 13757. The electricity meter communicates with the head-end system (HES) via LTE (G4 standard). As a result of the follow-up project, Honeywell was selected by Enexis as a supplier of smart ESMR5 gas meters.

In this respect and with a view to the forthcoming mass rollout both in the Netherlands and in Great Britain, Honeywell has now further developed the electronic index *themis*[®]. The new



Gas Meter BK-G4 ETeB with Electronic Index *themis*[®] *evolution* (ESMR5 Version)



themis[®]evo – 2nd Generation Electronic Index

index themis[®]evo (ESMR5 version) is based on the experience gained from the first generation of electronic indexes with a particular focus on highly automated production, energy-efficient operation, and wireless performance.

As a mandatory requirement, the new index can be used with all Honeywell residential and commercial gas meters. It is an integrated electronic index (on-board communication) with an LCD matrix display and a key to act as the user interface. One of the elementary requirements for the device is a battery life of at least 20 years. This is a massive challenge for a battery-operated device. Robust hardware and software design, outstanding production conditions with smart quality parameters, and excellent process capability are the requirements to achieve this. The battery can, however, be replaced to extend the meter's service life in the network.

The gas meter sends the electricity meter the measured volume at regular intervals using wireless M-Bus as well as event and alarm messages when necessary. Security measures to ensure integrity, confidentiality, and authenticity during the data exchange process between the various communication partners are also elementary requirements of Enexis. Together with external data security experts, extensive tests on how these are implemented were carried out. A secure, over the air firmware update guarantees that the technology is future-proof and can be updated to meet new requirements if necessary.

One special feature of the new index is that it displays the volume at base conditions. Using an integrated electronic temperature measuring system and a fixed value for the pressure, the measured volume is converted by calculation into a volume at base conditions (base temperature $T_b = 0^\circ\text{C}$, base pressure $p_b = 1013.25 \text{ hPa}$), shown on the display, saved in the index, and transferred to the head-end system via the electricity meter.

In addition to the over the air firmware update, the new product features which the ESMR5 gas meter can boast compared to its DSMR predecessor include sending the current meter reading to the electricity meter every five minutes (M-Bus C mode), which can then be shown to the end customer, for example, using an in-home display. The energy is supplied via a D cell, which can be accessed using a service interface. The communication unit including antenna is no longer modular (in other words, replaceable in the field) and alternative communications technologies (e.g. ZigBee) are implemented in the EMS production process by means of different equipment variants.

Inextricably linked – the new functional requirements for smart meters and the enormous demand could only be satisfied in highly automated production environments. Furthermore, efficient project management by both Enexis and Honeywell was a major factor for the successful implementation of the project.



In addition to careful product development and extensive testing, the success of smart metering in general is heavily dependent on a safe, high-quality production environment. Successful implementation of data security, service life, cost efficiency, traceability, and lead time requirements originate in the production of the devices.

In addition, the ESMR5 project is a very good example of close cooperation with our customer Enexis Netbeheer from an early phase and throughout the project period, extending from technical details and logistic processes

Networked Products – Electronic Indexes for Diaphragm Gas Meters G4-G100 from Honeywell

	<p>themis® – the new generation of electronic indexes from Honeywell for residential, commercial and industrial diaphragm gas meters.</p>
	<p>Combination of state-of-the-art technology with the experience gained from over 1.5 million installed diaphragm gas meters with electronic indexes.</p>
	<p>Supports various standards for communication and corresponding protocol variants (wireless M-Bus, ZigBee, GPRS, etc.).</p>
	<p>Design (hardware and software) optimally tailored to battery operation. Firmware update, event and alarm messages, LCD dot matrix display.</p>

to complex contractual matters. Reliable communication and consistent work using generally accepted project management methods have ensured clear structures and an identical understanding of requirements and expectations.

During the course of the project, it was decided to change to the LTE (G4 standard) communications standard, which is new to this application, in order to ensure the equipment is future-proof. Extensive adjustments to the hardware and software (e.g. the use of narrowband filters and the “Listen before talk” method (LBT or CSMA) to avoid data collisions) were required to satisfy the new requirements and ensure the reliable coexistence of LTE and wireless M-Bus, both of which send and receive in the 868 MHz frequency range. This modification, which was a major one initially, saw Enexis pave the way for a wide range of possibilities in the smart grid since LTE allows for real-time communication at high transmission rates and a wide range of applications in network management as well as supporting the use of future technologies such as narrowband IoT (NB-IoT).

The project teams at Enexis, Honeywell, another gas meter manufacturer and the manufacturers of electricity meters discussed the ESMR5 specifications in constructive talks, overcame outstanding questions and feasibility problems and thus defined a joint, binding solution.

The gas meters developed by Honeywell and tailored to the new challenges have undergone intensive testing, for example of their transmission and reception properties and their sound



In June 2017, Enexis Netbeheer started large-scale rollout of next-generation smart gas meters from Honeywell. This mass rollout follows successful joint development, testing, and implementation by Enexis Netbeheer and Honeywell including final system integration, field testing and wireless M-Bus radio testing by an accredited third-party laboratory. One and a half years after the start of development, Honeywell is able to deliver G4, G6, G10, G16 and G25 gas meters to Enexis Netbeheer for mass rollout.

Through the use of wireless M-Bus communication, Honeywell's ESMR5 smart gas meters are fully interoperable with all ESMR5-compliant smart electricity meters. This new combination of electricity and gas meters will offer near real-time information on energy consumption in order to reduce energy usage and significantly decrease energy costs for customers.

Preparation for the large-scale rollout started in December 2016 when Enexis Netbeheer deployed 30 Honeywell ESMR5 gas meters in the field for extensive radio communications testing. After a successful deployment where the Honeywell meters performed very well, Enexis Netbeheer began controlled rollout in April this year. This deployment also went smoothly. During this period, Enexis Netbeheer prepared the start of the mass rollout in detail while Honeywell made its final preparations to start mass production.

As of June 2017, Enexis Netbeheer has deployed ESMR5 smart electricity and gas meters in which the Honeywell gas meters perform in accordance with the ESMR5 specifications and without any significant issues in the implementation phase. The transition to full-scale production has now been completed and during the development, test and implementation phases, cooperation between the Enexis Netbeheer and Honeywell teams has been outstanding. Enexis Netbeheer is now eager to deploy ESMR5 smart meters at full speed to complete the mass rollout in the Netherlands in the next 3.5 years.

About Enexis Netbeheer:

Enexis Netbeheer is the regional network operator in the north, east and south of the Netherlands. The company is responsible for the development and construction of energy distribution networks (gas and electricity) and the maintenance and management of these networks. Acting as the link between the customer and the energy supplier, Enexis Netbeheer is responsible for the supply of energy to more than 2.7 million customers. Enexis Netbeheer has 4,500 employees.

transmission, by external laboratories and others. The products of all meter manufacturers had to prove that they satisfied all the requirements relating to communication, (data) security, tamperproofness and metrological accuracy in various tests conducted by Enexis and external laboratories and audit partners. Particular attention was also paid to the reliability of the products in terms of their mechanical, electronic and software features. Enexis and Honeywell worked particularly closely together for this purpose to ensure a service life for the gas meters of at least 20 years.

After the ESMR5 gas meters had also passed the Enexis product acceptance tests, they were transferred from development to mass production accompanied by various audits conducted at Honeywell and at suppliers' premises. A lengthy initial installation phase of new meters at Dutch end customers planned minutely was successfully completed in the second quarter of 2017, leading to the next phase, the mass rollout of the new smart energy meters.

Axel Bußkönning	axel.busskoenning@honeywell.com
Daniela Lücke-Janssen	daniela.luecke-janssen@honeywell.com
Carsten Lorenz	carsten.lorenz@honeywell.com
Cees Euser	cees.euser@enexis.nl

Market Launch of High-Pressure Gas Regulator HON R100 NG

The time-tested gas pressure regulator R100, which was previously marketed under the Gortor brand and has been in use for many years around the world, has undergone a thorough redesign to ensure that it meets customer requirements even better. This step will enable our customers to react to changing operating conditions. Here, growing cost pressure on the maintenance and operation of gas pressure regulating systems is the key issue.

Fig. 1: HON R100 NG 2" Class 600

During the development of the new R100, focus was consistently placed on minimizing maintenance both in terms of service parts and the work required. Thanks to its smart design, the number of pressurized parts and connection elements, such as screws and nuts, has been reduced by 50%. These facts, which sound unspectacular at first, actually mean that the time required for maintenance work can be halved compared to the predecessor model or a comparable competitor model. The time-tested valve disc seal, which is located outside the gas flow, has been adopted from the predecessor model and ensures lengthy trouble-free operation even if the gas contains impurities (Fig. 3).

The valve disc itself can now be removed from the housing for maintenance work in a matter of minutes using a plug connector. All the work can be carried out on the system itself – the device does not have to be removed to do so. Furthermore, compared to its predecessor, the weight of the device has been reduced by up to 40% depending on the nominal size. This also makes installation and handling during maintenance work significantly easier.

Naturally, the time-tested integrated sound reduction is still available for reducing the sound where it is generated. This revision has resulted in an increase in the flow rate of devices with integrated silencers of 30%.

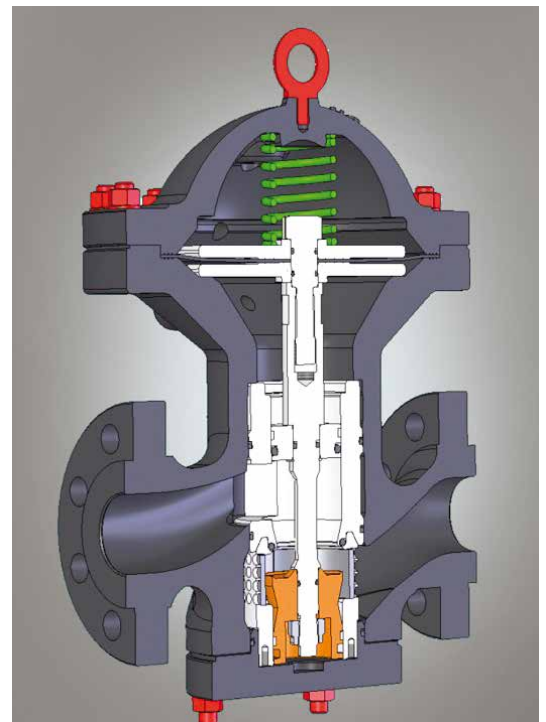

Fig. 2: Sectional View of HON R100 NG 2" Class 600, Fail-open

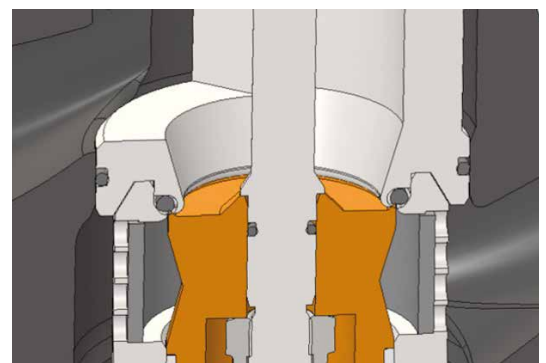

Fig. 3: Protected Valve Disc Seal



Fig. 5: HON R100 with Optical and Electrical Remote Position Indicator



Electric Remote Position Indicator



Optical Local Position Indicator

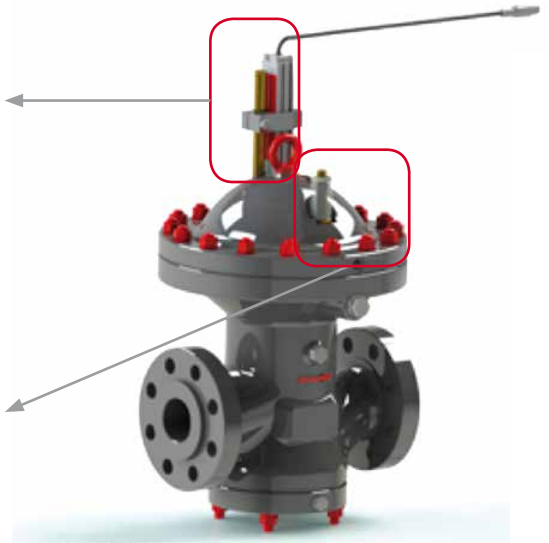

Other improvements can be seen as a result of the use of new guide elements with improved slide properties which also further enhances the control accuracy.

Another major plus point of the new HON R100 is its enormous versatility which enables it to be used in a wide range of the most diverse system designs. Honeywell can supply the gas pressure regulators in both a “fail-closed” and a “fail-open” version. Furthermore, there is a special monitor version in which the gas is routed below the valve disc of the monitor used to equalize the system’s outlet pressure. In addition to the classic application in combination with a safety shut-off valve, all these options mean that a wide range of active monitor applications can be covered, such as fail-open active, combined with the fail-closed monitor (Fig. 4).

For monitoring, the HON R100 can be fitted as an option with an optical position indicator and also with an electrical remote position indicator – both in combination or separately. There are two independent, easily accessible installation positions on the top of the measuring unit for this purpose (Fig. 5).

And there is no need to go without the benefits of the previous model. The two are completely compatible in terms of function. Its familiar high control speed makes this device the ideal

Main Features of the HON R100 NG

- Nominal sizes: 1"-8" (NG design) 10"- 16" (classic dome type design)
- Pressure ratings: CL150, CL300, CL600
- Outlet pressure range: 0.5 – 100 bar
- Failure mode: fail-open / fail-closed
- Monitor or active design
- NACE conformity

choice for gas turbine applications and for transfer stations in public gas supply systems. The new HON R100 NG holds DVGW approval to PED and EN 334 as well as SIL 2 certification. The regulator also complies with NACE Standard MRO175.

Sascha Bluhme sascha.bluhme@honeywell.com

Fig. 4: Fail-open Active, Combined with Fail-closed Monitor

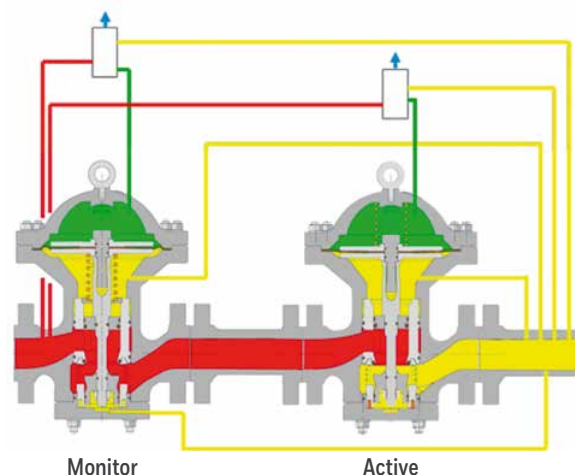

Introducing the GT Line of Turbine Meters with Top-entry Design

In our last Profiles magazine, we looked back at 90 years of success of our turbine meter product line. Most of you will have read about our European-style turbine meters in the past. But did you know that we also manufacture top-entry design turbine meters in the United States?



The American Meter Company has a long history of manufacturing robust and reliable diaphragm meters for residential applications but also manufactures a line of turbine meters called the GT and AccuTest series.

These meters are designed to accurately measure natural gas, air, nitrogen, and other non-corrosive gases for large-volume commercial and industrial uses. Meters are available in sizes ranging from 3" (DN 80) to 12" (DN 300) and operate in a temperature range of -40°F to +140°F (-40°C to +60°C).

In contrast to the Elster® lines TRZ2 and SM-RI-X, the GT and AccuTest meters are designed and manufactured according to American Standards (e.g., ASME, AGA Report Number 7), not European standards like PED or EN 12261.

In total, 4 different models are available which are described in more detail below:

1. GT: The GT is a turbine meter for basic applications available in 3" & 12". It has an integrated flow guide and a 45° plastic rotor, and the main bearings can be lubricated with a lubrication pump kit.

2. GTS: The GTS is available in sizes 4" to 8" and has both inlet and outlet flow guides to optimize flow condition even downstream of the meter. Thanks to the pre-machined housings, GTS meters can be subsequently upgraded to AccuTest models by exchanging the meter internals (cartridges).

3. GTX: The GTX is the most economical turbine meter in the portfolio and is available in sizes 4" to 6". In contrast to the other models, the GTX is designed with permanently lubricated bearings which reduces the need for maintenance in the field.

4. AccuTest: The AccuTest is a self-proving turbine meter with inlet and outlet flow guides. The main difference to the GTS is that the AccuTest meters have a second, independent reference cartridge built in which enables online comparisons and diagnostics. The meter is fitted with aluminum rotors only and has two high frequency outputs installed as a standard. This model is available in sizes 4" to 8".

All meters come with a mechanical index as a standard but can also be delivered with an instrument drive if that is the preferred way to transmit the volume from the meter to the electronic volume corrector. Low, medium and high frequency outputs are also available depending on the model.

Due to the top-entry design, these meters allow for easy maintenance as pre-calibrated measurement cartridges can be simply "dropped in" in the field reducing the required downtime significantly.

Interested? For more information about these turbine meters, please contact your account manager who will be happy to be of assistance.

Tim Vogel

tim.vogel@honeywell.com

Honeywell CNI4

The CNI4 is a 4G/LTE, battery-operated, easy to configure dual-channel pulse data logger designed to support most commercial & industrial (C&I) smart metering/automatic meter reading (AMR) analog modem-based applications.

With this advanced cellular pulse data logger, both input channels and stored consumptions can be independently scaled to different units of measure, providing maximum value and flexibility.

The CNI4 pulse data logger is designed for low-power and outdoor operation. It is ideal for call-in applications involving meter data management (MDM) and can directly connect to PowerSpring or couple with the InvisiConnect software to interface with third-party MDM systems.

The CNI4 is fully integrated in the Honeywell Mercury® instruments ecosystem and is easy to program through its Bluetooth Low Energy interface and associated configuration software. The unit can be configured using the same MasterLink software that is used to configure Honeywell Mercury electronic volume correctors, data loggers and modems. No additional software is required. In addition,



Main Features of the CNI4

- Two independent output channels
- Low power requirements: 8 years with 4 lithium batteries
- Field-proven composite material case with hinged door
- Easy software-based configuration
- Multi-vendor data collection capability
- Force-a-call feature
- Wireless communications: Cloud Link 4G cellular modem
- Power control: Intended for battery-operated wireless modem operation

MasterLink is now available as an app that can be installed on iOS and Android devices.

The CNI4 is CSA Class I Div 2 approved, making it the perfect solution for gas measurement applications where safety is always a concern.

Pierre Dufour

pierre.dufour@honeywell.com

EK280 – Perfectly Prepared for ALL-IP

On October 1, 2017, Honeywell will be supplying a new generation of modems for use in 2G and 3G networks for volume conversion device EK280 and function extension unit FE260.

Together with updated firmware (Version 2.50), the range of uses for the volume conversion device in terms of data communication will be significantly expanded. This means that the device is perfectly prepared for the requirements of ALL-IP infrastructure.

For years, Honeywell volume conversion devices and data loggers have been supporting both PULL mode (TCPServ: the devices are read from a control center) and also PUSH mode (ComFTP: the devices themselves initiate the transfer of data to the control center). However, in the past it has always been necessary to decide on one of these modes in advance since the function was provided by an application in the modem itself. This decision will no longer have to be made in the future. Both functions are now provided by the volume conversion device (Fig. 1). The modem itself will only provide the data communication channel to the cellular network. In addition, there is a general time synchronization option using a time server in the network (NTP). This is no longer limited to the use of the modem application ComFTP.

Particularly now, in the context of the change to ALL-IP, the possible alternative use of both types of data transmission in a single device will be extremely important if the data is still to be transferred from the measuring point to an FTP server at a control center (PUSH).



EK280 With the New Modem Generation for Use in 2G and 3G Networks

Why is this extremely important?

At the current time, as long as supported by the SIM card and the cellular network operator, it is generally possible to establish a “traditional” dialing connection to the modem using the GSM network (CSD service). This makes it possible to read the volume conversion device if, for example, a check or interim reading is required. This method is also currently used for maintenance work (e.g., setting and adjusting the parameters for the gas analysis).

Fig. 1: PUSH and PULL now possible independently of the modem application

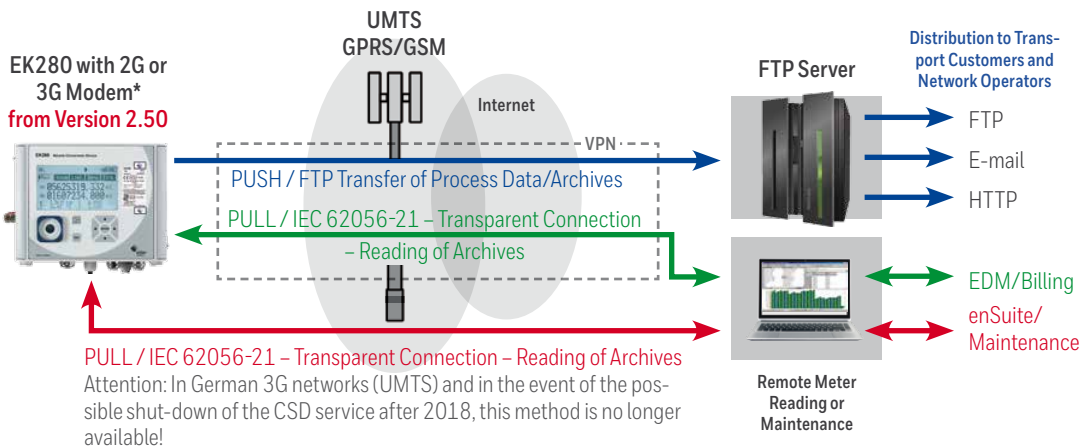

* Also in conjunction with function extension unit FE260

Abbreviations

- PULL** The call software initiates the connection to the device and reads the data.
- TCPServ** Honeywell's designation for the application in the volume conversion device or data logger which constitutes a server function. This enables the data to be read using the "PULL" principle. This application allows for bidirectional data communication.
- PUSH** The device automatically sends the data to a control center.
- ComFTP** Honeywell's designation for the application in the modem which reads the data from the volume conversion device or data logger. The data is placed on an FTP server using the FTP protocol. This application does not allow for bi-directional data communication.
- FTP** The File Transfer Protocol (FTP) is a standard network protocol used for the transfer of computer files between a client and server on a computer network.*
- NTP** Network Time Protocol (NTP) is a networking protocol for clock synchronization between computer systems over packet-switched, variable-latency data networks.*
- GSM** GSM (Global System for Mobile Communications, originally Groupe Spécial Mobile) is a standard developed by the European Telecommunications Standards Institute (ETSI) to describe the protocols for second-generation digital cellular networks used by mobile phones.*
- CSD** In communications, Circuit Switched Data (CSD) is the original form of data transmission developed for the time-division multiple access (TDMA)-based mobile phone systems like Global System for Mobile Communications (GSM).*

* Source: Wikipedia 03/08/2017 / 13:02:00 CET

The network conversion to IP technology will no longer necessarily guarantee the availability of the CSD service in the GSM network (GSM/CSD) after 2018. Furthermore, the CSD service is not available at all in Germany in the 3G network (UMTS). This means, however, without GSM/CSD and using PUSH mode, the control center or the parameterization software can no longer establish a connection to the volume conversion device. Thus, using only PUSH mode will become a one-way street!

And what does this mean for existing devices?

If you currently receive the data via an FTP server, the EK280 and the FE260 should be updated for the use of the new modems. In addition to replacing the communication module, a software update in the EK280 to Version 2.50 is required. You can request the change as part of the periodic calibrations carried out by the Honeywell Customer Service team. Bundling these activities is particularly effective because it will save both time and money.

This once again confirms that the modular concept of the EK280 using communication modules together with the progressive feature of a software download and a comprehensive range of services will secure your investment in our measuring technology.

Rüdiger Pfeil

ruediger.pfeil@honeywell.com

“E-mail for You!”

Around 3 months ago, I received an e-mail saying: „Hello, this is a FC1.“ from a somewhat cryptic e-mail address. “Huh, these spammers are getting stranger and stranger ...” I thought. And, of course, I deleted it straight away.

A few hours later, one of our developers in the legendary “Flow Comp Developer Coffee Kitchen” asked me, “Did you get the e-mail?” Then it all became clear. Some time ago, we had discussed the idea of how we could replace the good old GW-Message (the former fault reporting software) using a modern method. E-mail was our first thought. So you see, this had aroused the healthy playful instinct of the motivated developer team in Dortmund and shortly afterwards came this first “test mail.” Now this function is a working add-on in our newly released firmware 03-24-A. Users can enable it and notifications are then sent to one or more e-mail address when the entry in the enCore FC1 fault list



Here is a list of the add-ons:

- enSuite now shows the device types in the device hierarchy.
- IP ports for MMS (configuration) and HTTP (remote control panel) can now be configured in the device and also in enSuite.
- Additional display of all totalizing indexes in Display Vpt
- DSfG logbook available
- DSfG meter totals available
- DSfG instance electronic gas meter fully available, incl. register archive for diagnostic data
- New pressure range of 0.9 to 6 bar MID approved for the Honeywell STA84L
- E-mail notification in the event of a change to the fault list

changes. Naturally, this requires you to be able to access an e-mail server in your company that sends these e-mails. The volume conversion device is only one link in the chain. We tried exactly that out with two network operators to be certain that there were no major problems. All popular server communication encryptions will, of course, be supported.

In addition to the messaging function described above, there are a few other interesting new features available. Not to mention the new enSuite version (3.9.1), which you can download from <http://www.elster-instromet.com/en/software-downloads>.

Michael Pellmann michael.pellmann@honeywell.com

Looking Back over 45 Years of Electronic Volume Correctors

Electronic volume correctors are the cash registers of gas distribution and gas transmission companies. The data delivered by electronic volume correctors is used by the gas utility companies to bill their customers and as such, directly impact on their bottom line. Availability of accurate billing data is critical and, therefore, accuracy and reliability are prime characteristics of the product.

The latest EC350 is the result of constant research and development and builds on the success of the ECAT, Mini, Mini-Max, and Mini-AT correctors. Unlike an ECAT, the electronic volume corrector is not just a standalone product but rather is part of an ecosystem which includes the product, the cellular radio, its configuration software and meter data management solution – with all elements tightly integrated to guarantee interoperability, cyber security, accuracy, and reliability.

Pierre Dufour pierre.dufour@honeywell.com



100% of North American gas utilities use Honeywell Mercury Instruments volume correctors, data loggers or pressure recorders.

Over **350,000** instruments have been deployed.

Over **50,000** instruments communicate over landlines.

3 of our 4 main product lines have been updated in the last 12 months.

The average lifespan of a product is **15** years.

Invest in Your Service – Supported by Honeywell

As the gas industry environment becomes increasingly automated and complex, operating companies often focus their investments on improving their skills in the use of new technologies. But the importance of asset health monitoring and maintenance should not be overlooked.

Honeywell’s Total Care Field Instrumentation Services for Elster products address the operational and business demands that gas firms face every day. Maintenance outsourcing and preventive maintenance strategies can provide relief from these challenges and improve the bottom line by optimizing safety, efficiency, reliability, and uptime. They can also ensure continuity in gas measuring processes.

Now, more than ever, there is a need to leverage investments in control systems, field devices, and data infrastructures. Changing markets, regulatory issues, and complex supply chains require accurate, reliable measurements across operations.

Measurement and control equipment is central to a safe and profitable business, and a potential critical point of failure. As the burden on these systems grows, so does the strain on people and processes supporting them.

Gas industry firms must address their entire operations from a business perspective to maximize return on capital expenditures. Undetected errors in measurement resulting in lost or unaccounted for gas can quickly erode profits, and the same goes for unplanned downtime.

Optimizing Asset Performance

As a leading global supplier of controls and instrumentation, Honeywell Process Solutions offers its Total Care Field Instrumentation Services for Elster products to help customers streamline start-ups and optimize their control system and instrumentation infrastructure. Honeywell’s solution provides personalized service and assistance throughout the life of automation assets.

Total Care Field Instrumentation Services for Elster products are backed by in-depth experience to support a wide range of metering equipment. Elster’s smart meters, software and data analysis solutions for commercial, industrial, and residential applications are recognized for their reliability, safety, and accuracy. In the gas, electricity, and water industries, they provide the capabilities and confidence needed for successful operations.

The goal of our Total Care Field Instrumentation Services is to stop operational problems from evolving into serious incidents or disasters. There is never a good time for vital equipment or instruments to fail. But with aging systems, increased complexity, and regulatory pressures, failure to get the right support can mean a fault is just the start of a problem.



Total Care Field Instrumentation Services address the primary threats to a facility's day-to-day safety, availability, and productivity. The comprehensive services portfolio is intended to reduce the likelihood of failures, shorten recovery times, and eliminate skills and knowledge gaps.

All our Total Care Field Instrumentation Services for Elster products are linked with one another in order to reduce problems that keep operations from performing at peak levels by:

- Reducing the probability of trouble through regular maintenance; managed software updates and security; and planned, structured migrations;
- Minimizing downtime when problems occur through access to readily available parts, on-call service, and remote connectivity for troubleshooting and repairs;
- Closing gaps in internal expertise with 24/7 assistance, access to safety and regulatory compliance experts, and tailored training programs.

Total Care Field Instrumentation Services for Elster products offer a global, common, and simple framework that helps operating sites transition from reactive maintenance to a more effective, planned, and profitable solution – avoiding surprises and unexpected expenditures. In particular, the services eliminate run-to-failure costs of repair and replacement.

Specific service deliverables include:

Site Survey: A comprehensive site survey provides an inventory of existing equipment, recommended instrumentation, and an evaluation of internal obstructions and external observations. It can also determine whether additional maintenance or repair will be necessary to help establish a preventive maintenance budget.

Product and System Integration: Service professionals provide integration and communication between other products and systems. They utilize the customer's scope of work definition and a detailed explanation of their desired operation.

Remote Monitoring: Instead of waiting for problems to occur, why not rely on experts to continuously monitor the condition of equipment, and collect accurate and reliable information? This helps to minimize support calls, reduces the number of unscheduled or unnecessary service visits, and increases uptime to further enhance productivity.

Device Diagnostics: In-situ flow meter verification determines actual meter performance in operation. Data collected on site and analyzed at the factory determines meter and installation conditions. The analyses can detect misreading due to installation effects and equipment damage, and forecast accuracy at minimum flow.



Verification and Validation: Services are offered to keep gas measurement devices in the best working order. Checking all equipment for the required accuracy protects businesses from costly measurement errors. Verification tests are tailored to specified tolerances to meet all necessary industry standards and contractual agreements.

Commissioning: Technicians provide the assurance that equipment installation is done correctly and perform a final inspection to mitigate the risk of any potential problems.

Calibration: End users in Belgium and The Netherlands can minimize process shutdowns with on-site check-ups and calibration of rotary and turbine meters. Eliminating the need to send equipment back to the factory, this solution can help reduce the costs of checking, calibrating and, where appropriate, repairing equipment. For other countries, calibrations can be carried out at our on-site certified calibration labs.

Training: Results-driven training – whether in-house or on-site – improves productivity, with instruction tailored to cover operation, commissioning, and maintenance.

Enhancing Maintenance Strategies

Honeywell's Total Care Field Instrumentation Services for Elster products look at the entire gas metering equipment lifecycle from a service perspective. The services employ the versatile Meascon™ system to optimize condition-based maintenance (CBM) in order to avoid any misreading or asset failures, and identify potential problems in advance.

Gas industry companies can use Meascon to evaluate the health and performance of critical metering equipment, and then take the appropriate steps to optimize its service longevity and overall lifecycle results. Users are able to implement effective preventive maintenance strategies and minimize instrument calibration requirements in order to reduce operating expenses.

Thanks to the Meascon solution, the condition of gas metering systems can now be monitored continuously by gathering relevant data that is available at the primary and secondary measuring devices in the field. The system automates 24/7 condition-based monitoring, detects problems before they occur, and helps to keep measurement uncertainty as low as possible.

Meascon allows for easy health monitoring of a complete metering system. Its powerful condition-based monitoring capabilities detect any significant change either in the flow meter itself, or in the process and environment in which it is operating.

When traditional time-based maintenance (TBM) is used, measuring instruments are calibrated at regular intervals, whether they need it or not. If a risk-based maintenance (RBM) method is applied, the calibration frequency is reduced after a satisfactory level of stability has been demonstrated. By contrast, with CBM, maintenance is only performed after one or more indicators show that the equipment is going to fail soon or that its performance is deteriorating – thus, service and repair are only carried out when needed.



With TBM and RBM, meters are calibrated even when nothing is wrong. Meascon's historical diagnostic information can be used as a basis to extend the calibration intervals specified by regulatory authorities. This, in turn, may result in a shift from a regime of "calendar-based" off-site calibration to off-site calibration "as required".

Value to Gas Industry Customers

Honeywell's Total Care Field Instrumentation Services for Elster products can help gas industry organizations of all types and sizes achieve their business objectives, reduce or contain operating and service costs, and keep metering assets running at peak levels of performance.

Knowledgeable and well-equipped support teams deliver proven, in-depth domain and product expertise. They provide the right solution for faster resolution of critical issues. Key benefits include:

Improved Safety: Total Care Field Instrumentation Services for Elster products help customers work with dangerous processes or environments. As essential measurement and control functions as well as the measured data are safeguarded and thanks to customer-oriented support for solving technical and operational issues, these services make safe operations possible.

Increased Reliability: Honeywell's services optimize the health of equipment assets to reduce incidents. They help prevent unexpect-

ed downtime and get equipment back up and running quicker when faults occur. Ensuring the right working conditions for a profitable business, this solution helps maximize uptime and minimize the cost of failures.

Greater Efficiency: The Total Care Field Instrumentation Services offering safeguards the precision, traceability, and quality control that determine business success. Thanks to their expertise in custody transfer applications where small errors can have a big impact, Honeywell service specialists can keep operations running efficiently, while keeping maintenance costs controlled.

With Honeywell's Elster products, customers have access to advanced technology for high-accuracy custody transfer and high-reliability gas pressure regulation. These solutions not only set the standard for accuracy and reliability, but thanks to a world-class organization delivering superior Total Care Field Instrumentation Services, they also provide an excellent lifecycle experience.

Key to an effective service solution is Honeywell's CBM system, Meascon™, which fully integrates Honeywell's high-pressure products (such as ultrasonic meters, flow computers and gas chromatographs) and takes performance to the next level. Meascon™ enables gas operators to implement effective preventive maintenance strategies and minimize instrument calibration requirements in order to reduce their operating expenses.

Louis Oquendo

louis.oquendo@honeywell.com

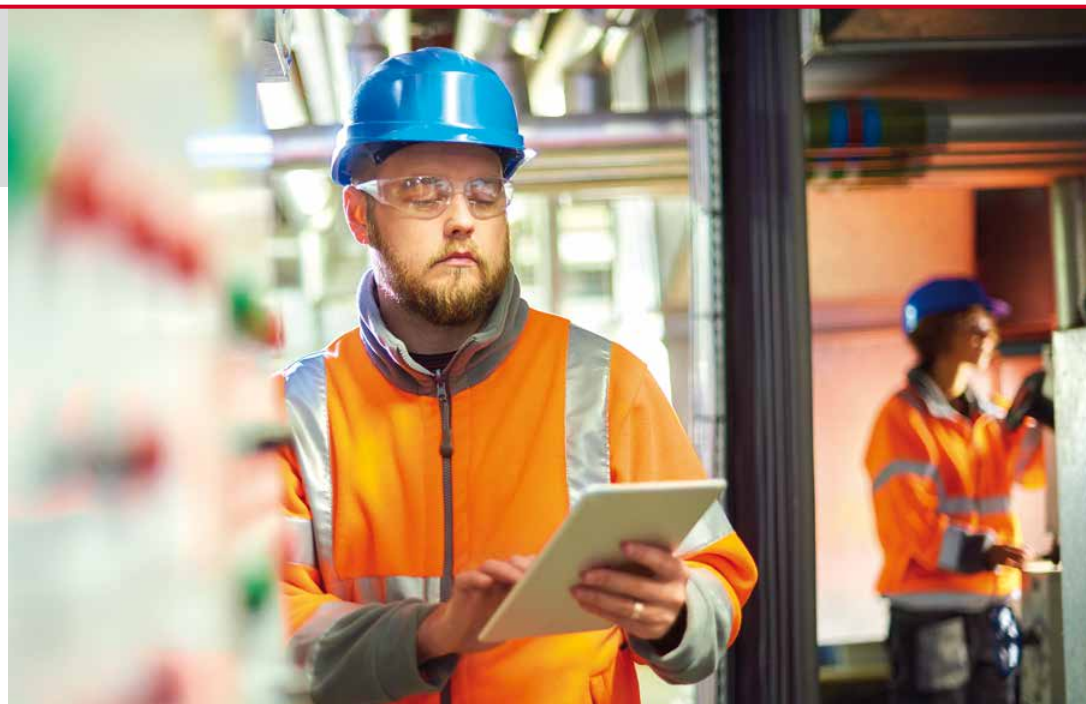

Huge Conference Success at AGA and HUG



In the first half of 2017, Honeywell’s Gas Metering and Regulation team again attended a massive number of trade shows and events to give our customers the possibility of interacting first hand with our products and the specialists who build them.

Large Crowds of Visitors at the Honeywell AGA Booth Presenting Our Product Highlights

For North America, the annual American Gas Association Conference and Exhibition is the clear highlight for the gas industry every year. This year, Honeywell showcased the new universal full end-to-end gas solution portfolio for the first time, ranging from residential metering and piping on the one hand, all the way up to high-end ultrasonic meters and our newest gas

quality devices on the other. In order to be able to display all this, we needed a massive booth as you can see in the pictures on this page. The feedback from our customers attending the show was outstanding – more than 500 customers visited our booth, and we performed almost 100 individual demonstrations.

HUG in San Antonio



Yet Honeywell does not only rely on third-party events to update and educate its customer base – from June 18 to 23, Honeywell held its very own Honeywell User Group Americas event in San Antonio. The interest, not only in our gas portfolio but also in our process and control solutions, was clearly manifested by an unprecedented 1500 people attending the show this year – leading to many of our fellow Honeywell colleagues having to search for alternative accommodation as the JW Marriott conference hotel was fully booked. For the first time, Honeywell offered conference attendees special discounts on certain product categories during the show, which was a great success, surpassing our internal target set for this initiative by more than 200%. The “Meet the Experts” round tables were also fully booked 10 hours every day, allowing our customers to analyze individual challenges in great detail and come up with new creative solutions.





Enough looking back! A trade show review would not be complete without highlighting an upcoming event, namely our European Honeywell User conference in The Hague, The Netherlands, from September 25 to 28. You will find all the products, solutions and conference offerings, and will be able to meet the experts who made the HUG Americas such a success PLUS you will have the chance to discuss the specific challenges, see the specific solutions and meet the local specialists for EMEA and your specific markets. The clock is ticking, so head over to your Honeywell EMEA User Group conference registration website at www.honeywellusergroup.com and secure your seat to ensure you get the information straight from the experts and have the opportunity to secure some great bargains for your company.

Max Gutberlet max.gutberlet@honeywell.com



HUG EMEA

Have You Seen This?

Fun From the Gas World

Thank you very much for the imaginative photos on the topic of gas! All those who send in contributions will receive a small gift as a thank you. Please send any amusing discoveries to: gudrun.biedermann@honeywell.com.



Gas Meter From 1927 (M. Schmitt, Germany)

Once upon a time... (A. Uhlig, Germany)



Elster GmbH

Steinern Straße 19-21
55252 Mainz-Kastel, Germany
www.elster-instromet.com

Honeywell Process Solutions

1250 West Sam Houston Parkway South
Houston, TX 77042, USA
1280 Kemper Meadow Drive
Cincinnati, OH 45240, USA
www.honeywellprocess.com

Honeywell